



The Finest Roll Covers, Toolboxes & Accessories on Earth!



Installation Manual

Roll Cover Installation Procedure

Please read entire manual prior to installation.
Installation Video also available to view at www.truckcoversusa.com.
Proper installation is the responsibility of the installer.

For questions or installation assistance, call our Help Line Toll Free in the U.S.
at (888) 808-2872 or direct dial at (858) 622-9135.



IMPORTANT POINTS TO REMEMBER AND CHECKLIST TO FOLLOW WHEN INSTALLING ANY AMERICAN ROLL COVER FROM TRUCK COVERS USA:

- 1.** Always centralize canister up front - see page 3, paragraph A. This will ensure a perfect front rail line-up. **BE SURE TO CHECK THE GAP BETWEEN CANISTER & FRONT BED RAIL TO SEE IF FOAM WEATHER STRIP IS NECESSARY. USE FOAM WEATHER STRIP ONLY WHEN NECESSARY TO FILL A GAP. (SEE PAGE 3, PARAGRAPH A. IN THE THIRD PARAGRAPH)**
- 2.** Always use the correct amount of shims, shims are **always** needed – side rails must be spaced the exact distance apart at the tailgate (end slat section) – see page 5, paragraph B. Fitting the side rails, continued. Once the correct gap is achieved, the remaining clamping sections are predetermined. You can now fill in the gaps (clamp sections at side rail & bedrail) with the appropriate amount of shims and complete clamping the side rails on each side. Always shim and clamp the rails at the tailgate before proceeding with the balance of the clamps. Once you have set the rails at the tailgate with the correct gap, you are ensured the correct gaps at the other clamping positions – just shim & clamp those remaining sections at the side rail & bedrail. Clamp holes are in fixed positions in side rails.
- 3.** The side rails should extend up to 3/8 inch onto closed tailgate top surface. - see page 5, paragraph B Make sure the underside of the side rail does not push against tailgate causing it not to close.
- 4.** Do not pull cover beyond tailgate. Make sure tailgate is always shut/closed when closing/locking the cover.
- 5.** Always make sure lock protection (cardboard protection underneath the lock as it comes from the factory) is under the lock every time you roll the cover into the canister before installing the canister lid. This will protect the underside of the lock from scratching the curtain. Once the canister lid is fully installed, there is no longer any need for the lock protection. Any time you are rolling cover out - remove cardboard.
- 6.** Do not forget to make final adjustment to lock block. - see page 7, paragraph D This will allow you to make final adjustment to the cover so it lines up with the side rails at the tailgate (allows cover to snug up to the tailgate).
- 7.** Always use caution when drilling drain hose holes so as not to damage truck outer walls – we recommend installing the drain hoses high enough as to keep hoses out of the way for loading items/cargo into truck bed. - see page 7, paragraph E Always make sure the drain hoses have a positive flow for any water.
- 8.** UTILITY RAILS – All models must have the utility or deck rail removed behind the cab if such truck has a utility or deck rail system option in order to centralize and place the canister properly for installation. See Install Manual for further details on options for such rails on the truck bed sides for different models. Please note that there is a drop down bracket kit available for purchase for the 07'-Up Toyota Tundra models in order to keep and use the side utility/deck rails.
- 9.** **NEVER LEAVE THE PULL STRAP UNSECURED. ALWAYS ATTACH THE PULL STRAP TO THE HOLDER PAD.** An unsecured pull strap may cause severe damage to the product or may cause serious injury. For maintenance or service questions, see paragraphs 6 & 7, page 11.

WARNING

- TRUCKS ALTERED WITH AFTERMARKET ITEMS MAY AFFECT THE INSTALLATION OF THE ROLL COVER.
Please consult our installation assistance line Toll Free in the U.S. at (888) 808-2872 or direct dial at (858) 622-9135, Monday-Friday, 7AM – 4PM PST. After Hours Helpline (858)342-9173.
- NEVER LEAVE THE PULL STRAP UNSECURED, AND ALWAYS ATTACH THE PULL STRAP TO THE HOLDER PAD.
An unsecured pull strap may cause severe damage to the product or may cause serious injury.
- DO NOT STAND OR JUMP ON THE ROLL COVER. Standing or jumping on the roll cover may cause personal injury.
- DO NOT PULL COVER BEYOND TAILGATE. Make sure tailgate is shut/closed when closing/locking the cover.
- **DO NOT ALLOW THE ROLL COVER TO ROLL BACK FREELY WITHOUT SECURE CONTROL OF THE PULL STRAP.**
Uncontrolled roll back of the cover may cause severe damage to the product and or personal injury.

Index

1. Introduction.....	1
Warning.....	1
Tools Needed for Installation.....	2
Items Provided for Installation.....	2
2. Unpacking and Preparing to Install Roll Cover.....	3
3. Standard Fitting Instructions.....	3
A. Fitting the Canister with Roll Curtain.....	3
B. Fitting the Side Rails.....	4
C. Fitting the Canister Lid.....	6
D. Adjusting the Locking Position.....	7
E. Fitting the Drain Hoses.....	7
F. Additional Information.....	8
4. Strike Plate Installation.....	9
5. Special Installation Fitting Instructions.....	10
(ONLY THESE MODELS)	
A. 2002-Up Dodge Ram Models.....	10
B. 2005-Up Toyota Tacoma Models.....	10
C. 2007-Up Ford Sport Trac Models.....	10
D. 2004-Up Nissan Titan Models.....	10
E. 2005-Up Nissan Frontier Models:.....	11
<i>Models CR205, CR305, CR306, CR801, and all Work Cover JR. covers have separate special instructions sheets provided with unit.</i>	
6. Maintenance.....	11
7. Service.....	11
8. Toolbox - American Work Cover.....	12
9. Terms and Conditions.....	13

1. Introduction

Thank you for purchasing our American Roll Cover Product for your truck bed! Built on experience, redesigned for truck owners, by truck owners, driven by consumer feedback, and made in the U.S.A. - the result is an evolution of perfection!

Please review the installation procedures outlined in the manual before you start installing your new roll cover. The notes and warnings offer key insights into our product and will help to ensure a smooth installation. At Truck Covers USA, we insist on a high level of customer satisfaction and carefully inspect each roll cover prior to packaging and shipping. If you have any questions/concerns about installation, accessory compatibility, product specifications, or other specific needs, please do not hesitate to call our Help Line Toll Free in the U.S. at (888) 808-2872 or direct dial at (858) 622-9135, Monday - Friday, 7AM - 4PM PST.

The Truck Covers USA team is extremely proud of our product and is looking forward to providing you with professional, expert service as long as you own your roll cover.

Sincerely,
The Truck Covers USA Team



TOOLS NEEDED FOR INSTALLATION

- Power Hand Drill
 - Hole Saw (1-1/4 inch/32 mm) - For drain hose holes
(1 inch for certain models with composite beds – no grommets needed)
 - Carpet Knife/Scissors - To cut drain hose sections
 - Wrench (Spanner) (9/16 open/ring) - To tighten clamps
 - 3/8" or 10mm Socket - For lid screws
 - 1/8" Drill Bit - For pilot hole for lock block screws
 - Screw Driver (Phillips head) - For lock block screws; self-tapping screws for L brackets on Dodge Models/special models
 - 7/16" Wrench - For strike plate nuts
- Note: All screws provided in kit.
- T27 Torx (for Sport Trac models only)
 - Tape Measure
 - Rust Preventative – For drain hose holes

ITEMS PROVIDED FOR INSTALLATION

- (1x) Canister with Roll-on Curtain includes end slat with lock
- (1x) Canister Lid
- (2x) Cover Keys Attached to Canister Bracket
 - Remove before installation
- (1x) Side Rail Assembly LH
- (1x) Side Rail Assembly RH
- (2x) Drain Hose
- Shims Package (varies from model to model)
- (4x) Drain Hose Grommets
- Side Rail Clamps (6x = Shortbed or 8x = Longbed)
- (4x) Lid Screws (black flange screws)
- (2x) Lock Block Screws
- (4x) Lid Screw Caps
- (1x) Foam Weather Strip (Pre-Installed on some select models)

● 2002-UP DODGE RAM MODELS

- (1x) Canister Support Bracket LH/(Left) L Bracket
- (1x) Canister Support Bracket RH/(Right) L Bracket
- (8x) Self-Tapping Screws (To secure L Brackets/4 each side)

● 2005-UP TOYOTA TACOMA MODELS

- Four (4) - Six (6) Special Bolts and Nylon Nuts (4 for Shortbed, 6 for Longbed) which are utilized for installation of the rails in place of the regular clamps. These bolts fit perfectly into the rail system of the Tacoma models and are then used to secure the side rails.
- The rails are provided with the Four (4) - Six (6) special mounting brackets already installed.

● 2007-UP FORD SPORT TRAC MODELS

- Four (4) Torx button machine screws are provided for this install. They each come with a heavy duty washer which gets screwed into the existing holes in the truck bed, one in the rear and one at the half way point on each side. The side rails come with the brackets secured in fixed positions which will line up with the fixed holes in the truck bed.

● SPECIAL INSERTS MAY BE PROVIDED FOR CERTAIN OTHER MODELS.

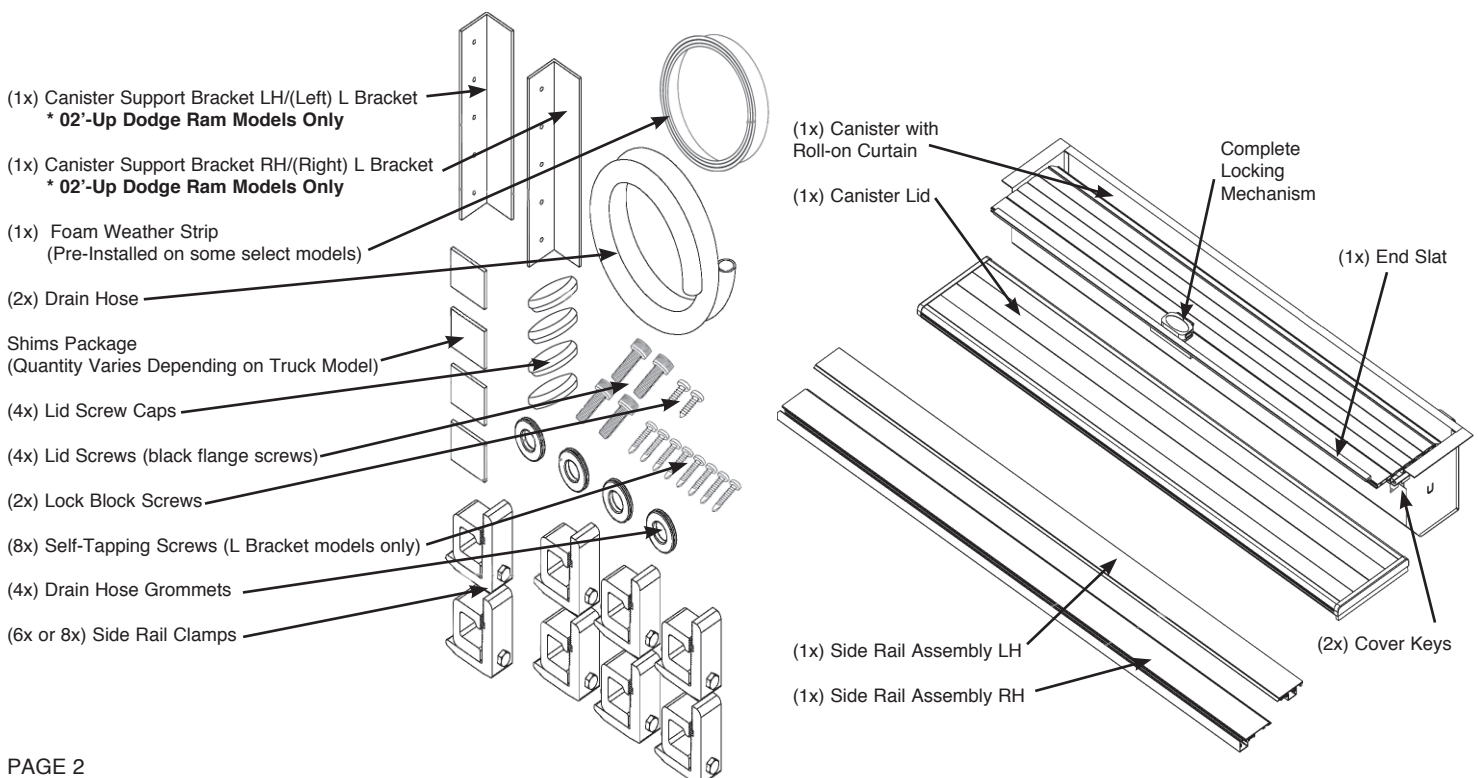

2. Unpacking and Preparing to Install Roll Cover

Note: Manufacturer recommends two people for certain steps of installation.

1. Locate spacious workspace.
2. Inspect condition of the box. If it appears that there is any damage to the box from shipping, notify our call center. If there is any visible damage to the packaging we have informed our Dealers/customers not to accept delivery of the cover unless they are certain that no concealed damage has occurred to the product. Manufacturer accepts no responsibility for damage in shipping once cover is accepted.
3. Confirm the make, model, and color marking on the box. The description should match the correct vehicle.
4. CAREFULLY REMOVE THE PROTECTIVE PACKING.
5. Compare contents with items provided for installation on page 2. If any parts are missing or damaged, notify our call center Toll Free in the U.S. at (888) 808-2872 or direct dial at (858) 622-9135, Monday-Friday, 7AM-4PM PST.

Note: Extra Shortbed = Four (4) Clamps, Shortbed = Six (6) Clamps, Longbed = Eight (8) Clamps. Dodge Ram models (2002 & Up) are the only models that require Canister Support Brackets/L Brackets. Toyota Tacoma models (2005 & Up) are the only models that require Special Bolts and Nylon Nuts. Ford Sport Trac Models (2007-Up) are the only models that require Special Button Socket Cap Screws (use existing holes in bed).

6. Lay items provided for installation out in an orderly fashion.
7. VERIFY TOOLS NEEDED FOR INSTALLATION (PAGE 2)
8. To prevent damage to the vehicle's paintwork, prepare vehicle for installation by covering the truck bed floor and open tailgate with protective covering (cardboard or blanket).

3. Standard Fitting Instructions

For 2002-Up Dodge Ram Models, 2005-Up Toyota Tacoma Models, 2007-Up Ford Sport Trac Models, 2004-Up Nissan Titan Models or 2005-Up Nissan Frontier Models refer to the Special Installation Fitting Instructions on page 10 for additional installation instructions before proceeding.

Note: Canister comes with drain plugs already installed. Do not remove protective foam covering drain plugs until ready to install drain hoses.

Note: If you are installing with a plastic drop-in bed liner, in most cases you must cut a minimum of 6" off the plastic liner straight across and down at the bulkhead (behind cab). This is necessary in order to fit the canister firmly in position. Plastic drop-in bed liners must also be "under the rail" models, or must be cut if they are an over the rail model. Roll cover will not install on top of over the rail plastic drop-in bed liners. Some situations may allow you adequate room to have the canister snug up against the bulkhead. Sealing is important so if it is determined that the plastic liner should be cut, then follow the directions herein.

A. Fitting the Canister with Roll Curtain

- Remove the keys from the Canister Bracket and store safely.
- Insert the canister into the truck bed with the lips of the canister resting on both sides of the truck bed (Fig. 1).
- Firmly push the canister with Roll-on curtain up against the face of the front panel of the truck bed.
- Position the canister in the CENTER of the bed. Incorrect positioning of the canister may cause damage to the Roll Cover.
- Foam Weather Strip - a piece of foam weather strip is provided with each cover. This foam weather strip is to be used only in the event that a gap is found between the canister and the front panel of the truck bed. It is difficult to gauge if the foam weather strip is necessary until positioning the canister. The foam weather strip is used to make up the difference in height spacing in trucks with plastic bed caps, etc. and when necessary to fill gap for an extra seal (meets metal up front behind the truck cab). All models differ with age and configuration in the need for the foam weather strip. The foam weather strip should be adhered to the truck bed unless you have a spray on bed liner and then you will need to adhere it to the underside of the canister lip since it will not stick to the spray on bed liner material.

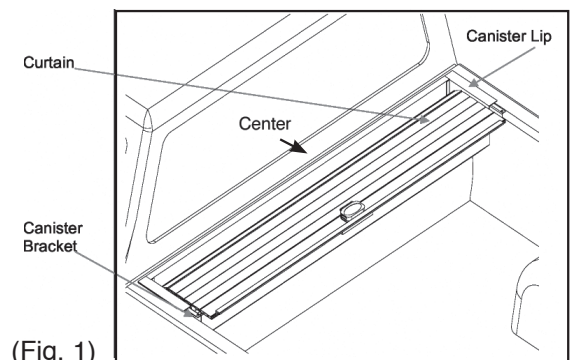

(Fig. 1)

B. Fitting the Side Rails (start with clamps at tailgate first)

Note: Do not remove the tape protecting the powder coating on the upper side until installer has completed the install and prior to installing the lid.

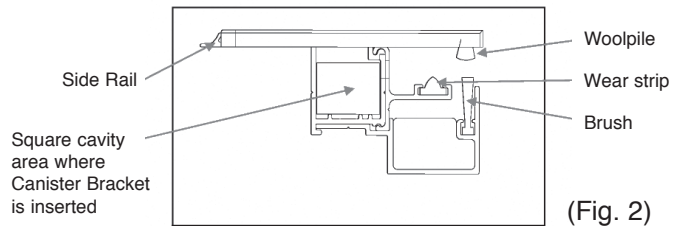

(Fig. 2)

- Locate the square cavity (Fig. 2) in the “LH” side rail and insert the “LH” rail bracket of the canister into this area sliding the “LH” side rail forward until it is up against the canister. The left drain channel on the side rail must protrude into the canister. The “LH” side rail can be moved back and forth as long as the drain channel remains in the canister.(Fig. 3) – Allows extra adjustment for side rails at tailgate.
- Locate the square cavity in the “RH” side rail and insert the “RH” rail bracket of the canister into this area sliding the “RH” side rail forward until it is up against the canister. The right drain channel on the side rail must protrude into the canister. The “RH” side rail can be moved back and forth as long as the drain channel remains in the canister.(Fig. 3) – Allows extra adjustment for side rails at tailgate.
- Check to ensure that the nylon wheel in the canister turns freely and is not jammed by the drain channel.
- If adjustment of unit is necessary to bring closer to tailgate for proper installation, side rails can be pulled away from the canister bracket. There is ample room for movement in this manner. NEVER pull the canister unit away from bulkhead.

Note: Curtain cannot be pulled until the side rails have been secured with the clamps and leveled. It is suggested that at least one clamp at each end near the tailgate position be secured before pulling the curtain to check installation and leveling of the rails. Unsecured and improperly installed side rails may cause damage to the side rails and curtain. Please be careful when rolling cover back into canister so as not to damage curtain. Insert lock protection to underside of lock area (cardboard underneath) whenever rolling cover back into the canister until the lid has been fully installed.

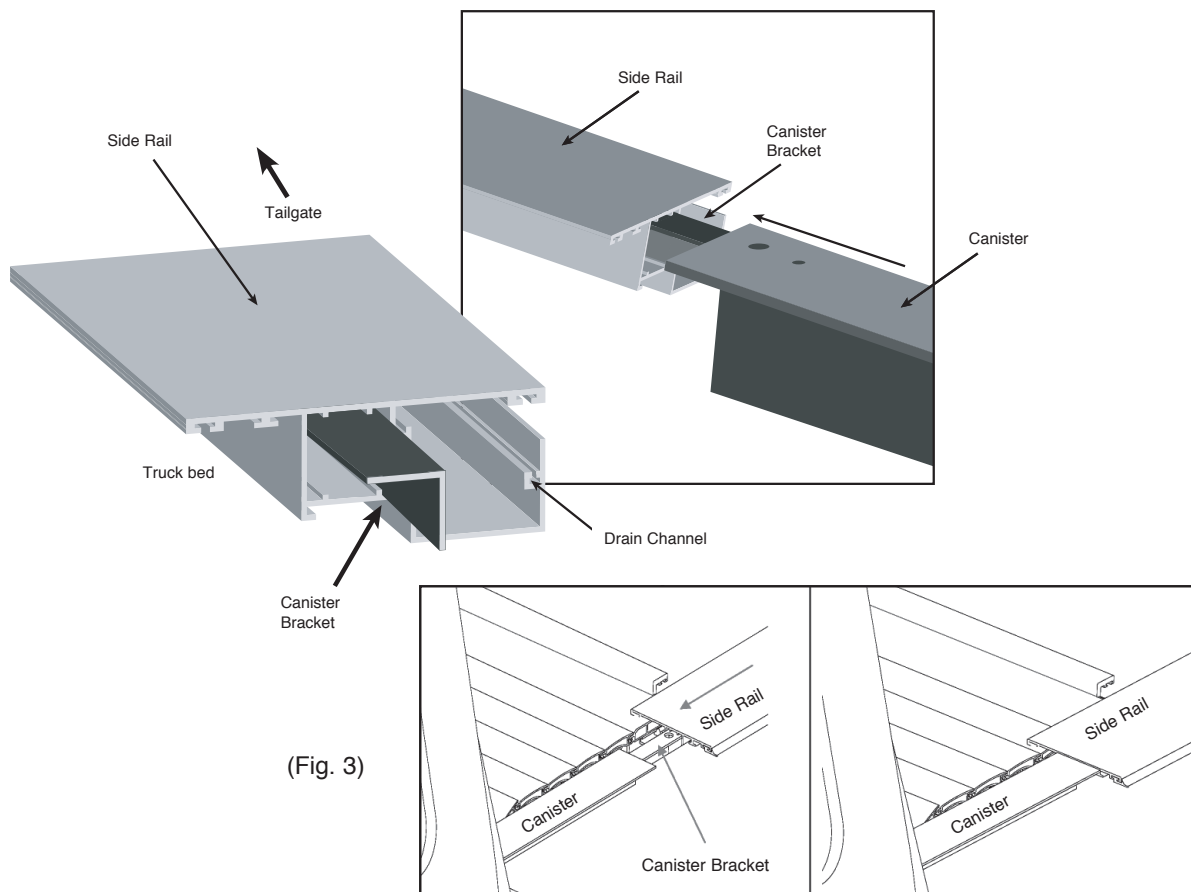

(Fig. 3)

B. Fitting the Side Rails (continued)

Note: Tailgate is to remain down until rails are inserted into canister bracket. Close tailgate carefully to begin clamping side rails. (Fig. 4a)

- Measure end slat (see Note below) adding 1/8" to total which will give you the perfect gap between the side rails (1/16" on each side).
- Before clamping, close the tailgate of the truck carefully making sure not to hit the rail end caps. It is suggested that clamping be done with tailgate closed to ensure proper side rail installation. Side rails should clear tailgate and not overlap more than 3/8 inch.
- Using one (1) side rail clamp and shim(s) (amount of shims varies from model to model), clamp the side rail clamp and the shim(s) at the left rear of the truck bed.
- Using one (1) side rail clamp and shim(s) (amount of shims varies from model to model), clamp the side rail clamp and the shim(s) at the right rear of the truck bed.
- Always use the correct amount of shims (this varies from truck model to truck model) – under-shimming can cause your rails to bow in.
- The clamps will hold the side rails in place so you can unroll the curtain to ensure that the curtain lines up with the side rails at the tailgate. If two people are installing the side rails, one should pull the rail tightly into the truck bed while the other installs the clamps (Fig. 4a). Two people recommended for first clamp at tailgate for both side rails.
- With the tailgate closed, adjust the side rails to extend up to 3/8" (10mm) onto the tailgate. (Fig. 4b)

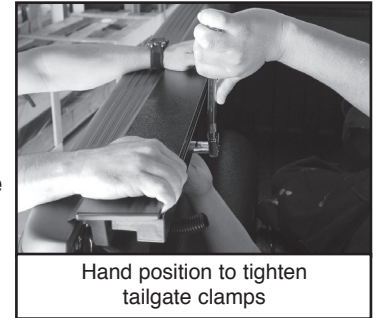

(Fig. 4a)

Note: The most critical gap for your rail fitting is at the tailgate. The perfect gap (width) is the distance measured of the raised end slat (slat with lock portion) with an added 1/16 inch for the right and 1/16 inch for the left. This should be the measured gap between your side rails at the tailgate of the truck (Fig. 5). You will need to choose the correct amount of shims to achieve this gap – once shimmed, secure your clamps on each side of the rails at the tailgate end. Once you have achieved this "perfect" gap at the tailgate and your rails are sitting level – it is just a matter of shimming the other clamping positions and clamping them down. All clamping should be alternated left to right. Do not clamp one side rail completely before the other. Alternate clamping will help to keep your rails positioned properly.

- If you have opened the tailgate during clamping, please close the tailgate carefully making sure not to hit the rail end caps.
- Then feed the cover into the rails and remove the lock protection. PLEASE NOTE IF YOU NEED TO RETURN THE COVER INTO THE CANISTER – REPLACE THE LOCK PROTECTION BEFORE DOING SO TO AVOID DAMAGE TO ANY SLATS. LOCK PROTECTION IS NOT NECESSARY ONCE THE CANISTER LID IS FULLY INSTALLED.
- Using the pull strap (attached to the under side of the curtain), pull the curtain along the side rails checking for sufficient clearance between the curtain and the side rail to prevent damage to the side rails.
- With the tailgate closed, the end slat of the curtain should come over the tailgate not more than (10mm) 3/8 inch.
- If you are certain your rails are installed accurately, you can install the Canister Lid (Section C) at this point if necessary.
- Very carefully allow the curtain to retract back into the canister (put lock protection under the lock).
- Insert a piece of cardboard between the underside of the lock and the curtain to prevent damage. LOCK PROTECTION IS NOT NECESSARY ONCE THE CANISTER LID IS FULLY INSTALLED.
- Draw out the curtain to ensure that it runs free of obstruction.

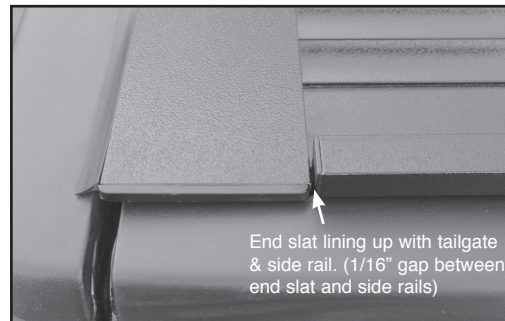

(Fig. 4b)

Note: If you find your rails are not sitting level, you need to check your SHIMS. Not the amount of shims, but the way they are installed. On all truck beds you will find that the profile of the metal has a bump at the top of the bed and then it recesses in. What you want to achieve is a vertical surface for the rails to clamp against (SEE Fig. 6). This is achieved by putting the smallest shim below the bump followed by a larger shim in front – thus, creating the vertical surface necessary.

Note: If you are working with plastic bed caps – you may need to put a small shim between the plastic and the metal bed rail below the bump to achieve the vertical surface necessary as well and prevent the rails from tilting into the bed.

Note: IF YOUR RAILS ARE LEVEL – NO ADJUSTMENT IS NECESSARY!

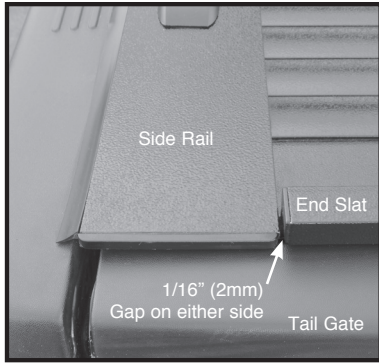

(Fig. 5)

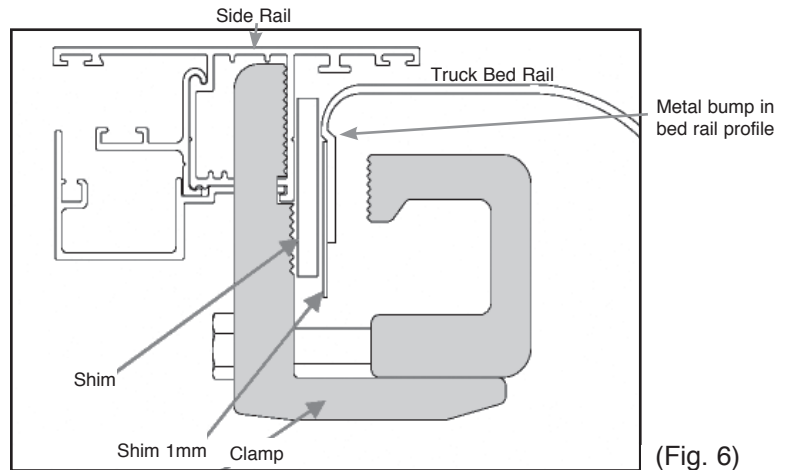

(Fig. 6)

B. Fitting the Side Rails (continued)

SHIMMING IS VERY IMPORTANT - Shims help you achieve the correct gap between the side rails!

Note: Once the tailgate clamps have been installed and the perfect gap has been achieved, the rest of the shimming and clamping is preset and you are merely filling in the gaps.

- Insert shims from the tailgate toward the canister by using the same size Shims on opposing sides at each clamped position. (tapered bed will use more shims)
- Install side rail clamps and shims – **ALTERNATING LEFT TO RIGHT SIDE UNTIL ALL CLAMPS ARE INSTALLED.**
- Make sure all clamps are secure and tightened.
- If the correct amount of shims are not used, it is possible to bend the rails – therefore, it is extremely important to fill the gaps before clamping with the appropriate amount of shims once you have leveled your rails.

Note: When clamping, shims must always be included. Shims allow for secure installation of the side rails. Shims of varying sizes are included in your Shims Package. As noted above, always use the smallest shim to fill the bump and then start with your next size up shim to fill the gap to achieve vertical surface (Fig 6.)

SHIMS GO AT EACH CLAMPING POSITION – between side rail and bed rail.

- **OPTIONAL** (Extremely wet conditions) – Seal the area where the drain protrudes into the canister (on the outside of the canister) with silicone sealer if necessary. (Fig. 7).

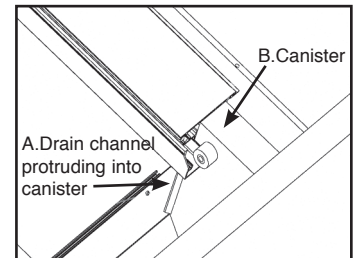

(Fig. 7)

C. Fitting the Canister Lid

- Draw out and lock the curtain in place.
- Remove the protective tape from the side rails.
- Place the canister lid over the canister at the front of the truck bed.
- Check to ensure the canister lid is positioned evenly on either side on the truck bed. The end slat bump rubber should face the tailgate of the vehicle (Fig. 8).
- Line up the holes on the canister with the holes on the lid.
- Using the lid screws (4x black flange screws), secure the lid into position and place on the lid screw caps (4x).

Note: Press down on Canister Lid while tightening lid screws to insure correct fitting. Do not over tighten the lid screws.

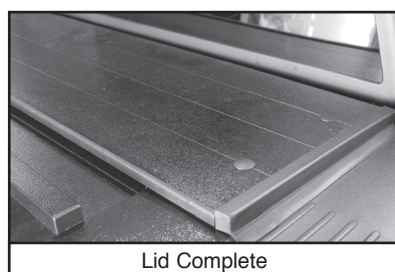
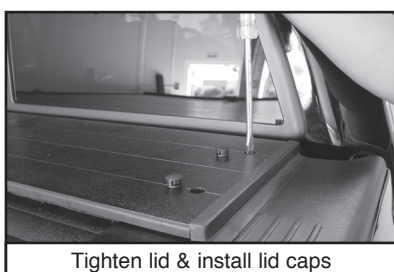

(Fig. 8)

D. Adjusting the Locking Position (Two people recommended) - NEVER REMOVE CENTER SCREW OF LOCK MECHANISM.

- Draw out the curtain until the end slat is level with the rear of the side rail. SIDE RAIL POSITIONS MUST BE CORRECT TO CONTINUE. Ensure that the curtain is snug up against the tailgate (side rails & curtain should line up as close as possible).
- Locate the side rail lock screw in the elongated hole at the bottom of the curtain. (Fig. 9) Shows the rear bottom view of the side rail where the side rail lock block adjustment screw is located.
- Adjust screw in the elongated hole on the underside of the side rail. Slide the screw which moves the lock block.
- Open the tailgate and move the lock block toward the tailgate until it is firmly against the extended lock bars while the cover lines up with the side rails.
- Check to ensure that the end slat remains lined up with the side rails. (Fig. 4b)
- Tighten the adjustment screw securing the lock block in place.
- Close the tailgate, making sure locking position is snug against tailgate and working properly before proceeding.
- Operate the locking mechanism (work the cover a few times to check adjustment if necessary).
- Once the correct locking position is located, secure the lock block. In order to secure lock positions, it is necessary to drill a pilot hole into the nylon lock block through the pre-drilled hole in the aluminum. The pilot hole is necessary to allow you to screw in the lock block screw easily. (Fig. 10).
- Check to ensure the end slat is in the locked position.

Note: Lock block needs adjustment in order to line the curtain up with the side rails at the tailgate. Once the correct locking position is located, proceed to drill the pilot hole necessary to secure the lock block in place (Fig. 10).

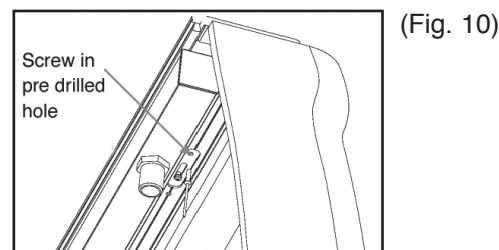
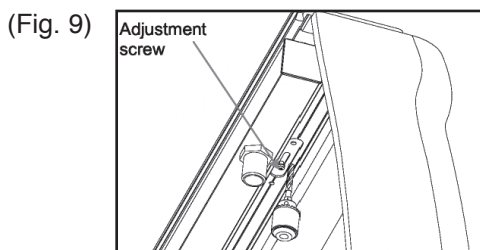

E. Fitting the Drain Hoses

Note: The following models only have one drain position in the canister (centered) – CR503 (Nissan Frontier S/B 2000-2004); CR243 (Chevy S-10 & GMC Sonoma S/B 1999-Up); CR260 (Chevy Colorado & GMC Canyon S/B 2004-Up); CR442 (Toyota Tacoma L/B 2005-Up); CR443 (Toyota Tacoma S/B 2005-Up); CR441 (Toyota Tacoma S/B 1995-2004).

Note: 1 inch hole saw should be used for certain models with composite beds without the use of a grommet. Drain hose should be inserted directly into 1 inch hole.

- Unlock the curtain and fully open the cover.
- Mark an appropriate spot on the truck bed approximately 5" (127mm) directly below the rear drain plugs installed at rear of each side rail at tailgate. Each truck model will have different drilling positions to avoid damage.
- With the 1.25" (32mm) Hole Saw, drill a hole through the inside panel of the truck bed (and liner) beneath the drain plugs at the position you marked (Fig. 12).

Note: The position of the hole is optional and can be positioned wherever the customer prefers it to be as long as it drains out of the truck bed. The manufacturer recommends hole location to be in an area where the drain holes will not be damaged by normal use yet high enough to avoid load damage. Care must be taken not to damage the outside of the truck bed. It is important to get a positive water flow through the drain hose.

- Apply Rust Preventative (NOT SUPPLIED) wherever drilling occurred in the truck bed.
- Fit two (2) Drain Hose Grommets in the drilled holes (Fig. 13).
- Cut a suitable length of drain hose and push one end through the hole in the grommet and the other end over the drain plug. (Fig 14)

Note: The angle of the hose should be sufficient to ensure a positive flow of any water. Ensure that the drain hose is not bent at a full 90 degree angle to avoid kinking. Also ensure that the drain hose is not pushed up against the outer panel of the truck bed. Both situations may cause blockage during wet weather.

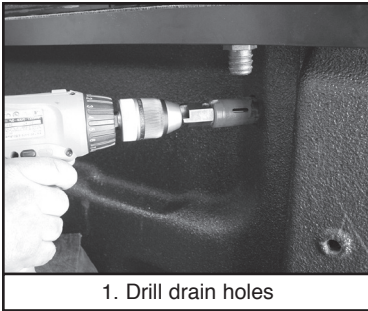

(Fig. 12)

1. Drill drain holes

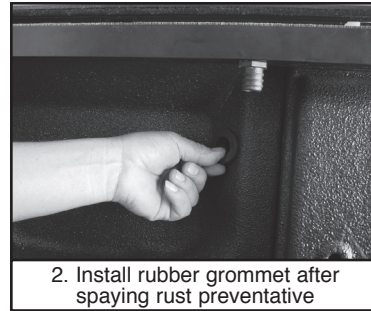

(Fig. 13)

2. Install rubber grommet after spaying rust preventative

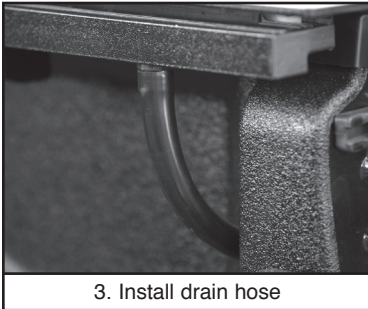

3. Install drain hose

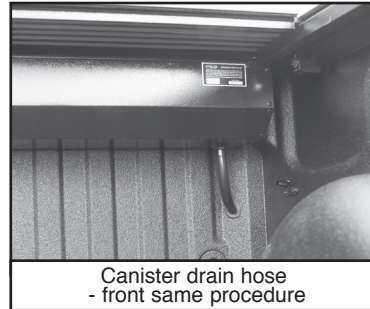

Canister drain hose
- front same procedure

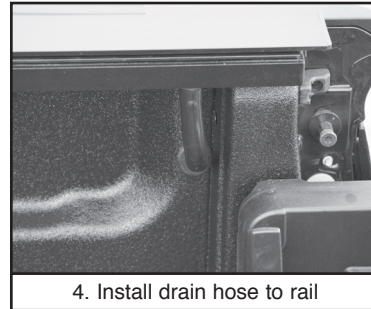

4. Install drain hose to rail

(Fig. 14)

E. Fitting the Drain Hoses (continued)

- Locate the two drain holes on the bottom of the canister and remove foam packing around drain plugs.
- Repeat the above procedure.

Note: The holes in the body should be drilled, where possible, through the front wall of the truck bed (Fig. 14). If that is not possible, the side panels may be used. **EXTREME CARE SHOULD BE TAKEN NOT TO DRILL THROUGH OR DAMAGE ANY CRITICAL PART OF THE VEHICLE.**

F. Additional Information

Pull Strap – Attached to the Roll Cover pull strap is a Velcro holder pad. Position near the tailgate on underside of side rail for ease of reach. The pad provides easy access to the pull strap and holds the pull strap inside the truck bed area when the vehicle is being driven with the Roll Cover open.

- Make sure you position the velcro pad on the under side of the drain channel and secure it.
- Always make sure the pull strap is secured and check the velcro pad periodically for damage.

WARNING:

ALWAYS SECURE THE PULL STRAP TO THE HOLDER PAD (VELCRO PAD). AN UNSECURED PULL STRAP WITH THE ROLL COVER OPEN MAY CAUSE SEVERE DAMAGE OR INJURY. THE MANUFACTURER RECOMMENDS THAT THE ROLL COVER BE CLOSED AND SECURED WHILE DRIVING WHEN POSSIBLE.

Unlocking & Opening Cover – You must relieve the tension on the cover slightly before turning the key or operating the keyless entry. Just pull the raised end slat toward you slightly and this relieves the tension to operate the lock properly.

Curtain Tension Adjustment – Needs to be performed by qualified installer as the curtain is under tension and can cause serious injury

4. Strike Plate Installation

Install the Strike Plate – Only once the Cover has been completely fitted to bed.

1. Install the complete Cover, including the Lid, as per the Installation Manual making all necessary adjustments and start with the cover in fully open position.
2. Now pull the Curtain into the first locking position so you can gain access to the key guard.
3. While maintaining the Curtain in this position, remove only the one nut on the Canister Centre that has nothing hanging on it. [The other nut has a bracket (Strike Plate) hanging on it].
4. Swivel the bracket (Strike Plate) and insert it onto the stud where you removed the nut in step #3, and place nut back onto this stud, and fasten in order to clamp the Strike Plate onto the canister firmly.
5. Fasten the other nut on Strike Plate and ensure both are tight and holding the Strike Plate firmly onto the Canister.
6. Now release the Curtain so that it retracts into the fully open position (up against the canister lid), towards the Strike Plate you have just installed.
7. When the Cover reaches the fully opened position, you should hear the lock and locking bars being released (Click), and you can now pull the curtain in the normal way to close the cover.
8. Your cover is now ready to use, and will automatically lock every 12" (in predetermined positions) until it reaches the final locking position at the tailgate. A key is only necessary to unlock the Cover.
9. When opening the cover using the key, pull the cover off the locked position slightly to release the tension and the locking bars – then turn the key from the 9o'clock position to the 12o'clock position (1/4 turn) until you hear the lock click – then return to the 9o'clock position and remove the key!

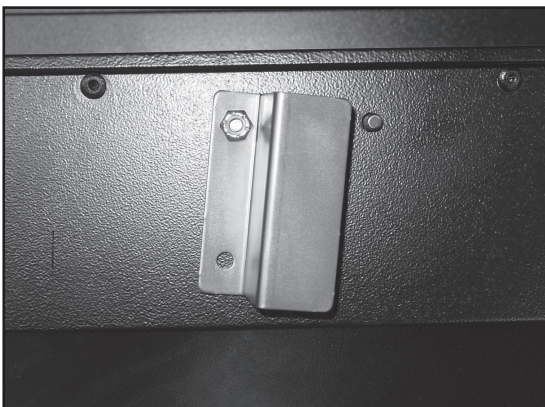
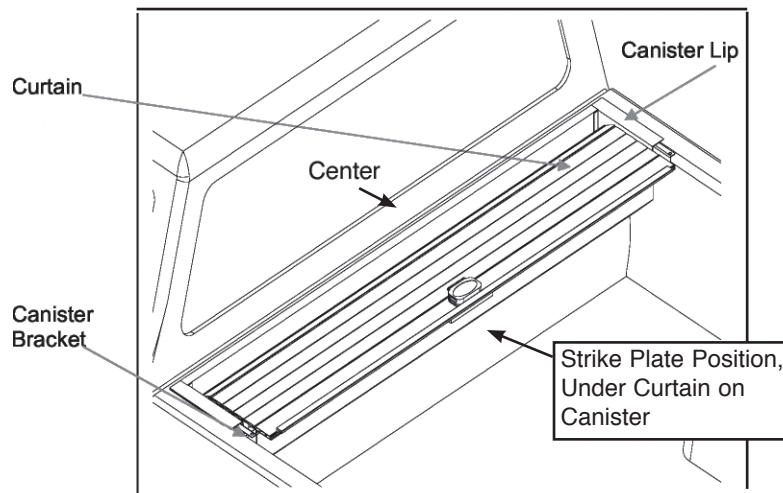

5. Special Installation Fitting Instructions

Note: Only these models require special installation instructions. For all other models, follow standard fitting instructions. SPECIAL INSTALLS STILL REQUIRE SHIMMING.

A. 2002-Up Dodge Ram Models

Tapered truck beds (Dodge Ram Models) – Vehicles with excessively tapered truck beds (the width of the truck bed behind the cab is greater than the width of the truck bed at the tailgate), must have additional brackets fitted. L Brackets are supplied.

- Position the canister support brackets (one left and one right) at the front of the truck bed (Fig. 15).
- Align canister support brackets with the top of the truck bed rail.
- Secure the brackets to the truck bed with the self-tapping screws provided in the kit. To secure the brackets, you must use four (4) stainless steel self-tapping screws per bracket.
- Proceed with the standard installation (see Standard Fitting Instructions, page 3).

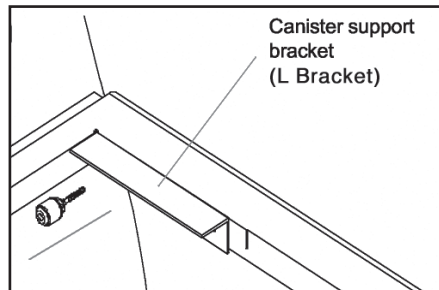

(Fig. 15)



Note: Insure brackets are level or a minimum of 1mm above (but never below) the bed rail to ensure correct positioning of the side rails. The brackets should be parallel with the inside of the bed rail. If the brackets are lower than the bed rail the side rails will pull inward making it difficult to level them.

B. 2005-Up Toyota Tacoma Models

The following steps must be taken in order to install a Truck Covers USA American Roll Cover on the 2005 & up models of the Toyota Tacoma w/utility rails:

- The American Roll Cover from Truck Covers USA for the Toyota Tacoma w/utility rails will come complete with four (4) - six (6)* special bolts and nylon nuts which are utilized for installation of the rails in place of the regular clamps provided with most other models. The rails are provided with the four (4) - six (6)* special mounting brackets already installed. These bolts slide perfectly into the rail system of your Tacoma and are then used to secure the side rails of your American Roll Cover.

Proceed with the standard installation (see Standard Fitting Instructions, page 3). Please remember that you are losing the function of the Toyota factory utility rail.

C. 2007-Up Ford Sport Trac Models

Four (4) Torx button machine screws are provided for this install. They each come with a heavy duty washer which gets screwed into the existing holes in the truck bed, one in the rear and one at the half way point on each side. The side rails come with the brackets secured in fixed positions which will line up with the fixed holes in the truck bed.

Proceed with the standard installation (see Standard Fitting Instructions, page 3).

D. 2004-Up Nissan Titan Models

The following steps must be taken in order to install a Truck Covers USA American Roll Cover on the 2004 & up models of the Nissan Titan:

STEP ONE: The manufacturer installed utility rails need to be removed & reinstalled upside down on both truck bed sides using the lower holes. You will utilize only 2 of the existing 4 holes/bolts when reinstalling the rails upside down (two per side).

STEP TWO: Now that you have taken the necessary step to lower the factory utility rails - you are now ready to install the American Roll Cover per the installation instruction manual. You are now sporting the finest roll cover on earth and also are left with the ability to use at least 2 (one left/one right) of the utility rail tie-downs Nissan provided with your Titan.

Proceed with the standard installation (see Standard Fitting Instructions, page 3).



5. Special Installation Fitting Instructions (continued)

E. 2005-Up Nissan Frontier Models

You have two (2) options to choose from for installation of this model. You can remove and reinstall the utility rails upside down. You will not be able to use one of the screws when you reinstall them upside down and they will therefore lose some of their strength. The utility rail behind the cab **MUST** be removed before installation. The customer will no longer be able to use the bed extender with our cover once installed.

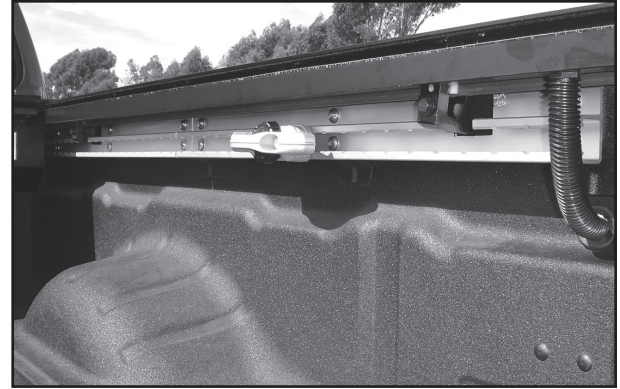

The following steps can be taken for your second option on this installation:

STEP ONE: The manufacturer installed utility rails need to be removed & reinstalled **AFTER** notching out an upper portion for the clamping positions of the American Roll Cover. It is extremely **IMPORTANT** to mark the position of the notches to be cut out of both utility rails. You will then reinstall the utility rails in their original position on both sides of the truck bed before beginning installation of the American Roll Cover. The utility rail behind the cab **MUST** be removed before installation.

STEP TWO: Now that you have taken the step necessary to make the slight modifications to the factory utility rails - you must place the tie-downs inside the rails in a position where they are between both notches for both clamps on each side (the tie-downs do not have the ability to pass by the American Roll Cover clamping system).

STEP THREE: You are now ready to install the American Roll Cover per the installation instruction manual. You are now sporting the finest roll cover on earth and also are left with the ability to use all four anchor points of the utility rail tie-downs Nissan provided with your Frontier.

Proceed with the standard installation (see Standard Fitting Instructions, page 3).

6. Maintenance

The Roll Cover was designed for ease of operation, low maintenance, and minimal service requirements. To ensure a long, trouble free life of the Roll Cover, it is important to follow the instructions below:

- Leaves, Dirt, Debris, etc. should be removed from the top of the cover if evident before opening.
- Never apply any kind of grease, lubricants, sprays or oil-based products to any part of the roll cover.
- Use only mild soap and water to wash the cover. Never use any Chemicals, polishes or waxes on any part of the Roll Cover.
- In extreme dry conditions, silicone spray may be used inside the side rails to help the cover slide & operate more freely.

Note: IF CURTAIN DOES NOT ROLL FREELY – YOU MAY CHECK FOR OBSTRUCTION AND REMOVE ANY FOUND. A SILICONE SPRAY MAY BE USED FROM TIME TO TIME TO SPRAY INTO THE SIDE RAILS TO HELP THE COVER SLIDE & OPERATE MORE FREELY. IF CURTAIN STILL DOES NOT ROLL FREELY – TENSION MAY NEED TO BE ADDED TO THE SPRING. WE SUGGEST THIS ONLY BE DONE BY A CERTIFIED INSTALLER. NEVER FORCE COVER OPEN OR CLOSED. IF NOT OPERATING PROPERLY, CONTACT THE INSTALLING DEALER OR OUR CALL CENTER.

7. Service

If you experience any trouble with the operation of the Roll Cover see note above. As long as cover works properly, service is not necessary. If service becomes necessary, contact the nearest service center (installing dealer) or our call center at (888) 808-2872, Monday-Friday, 7AM – 4PM PST, or direct dial at 858-622-9135

We suggest servicing by a certified service center or qualified installer. The following items should be checked during any service:

- | | |
|---|---|
| <ul style="list-style-type: none"> • Spring tension and curtain operation • Side rail wear strip • Lock and locking position • Locking Position Inserts | <ul style="list-style-type: none"> • Drain channels • Drain hoses • Velcro pad |
|---|---|

8. AMERICAN WORK COVER (TOOLBOX) INSTALLATION INSTRUCTIONS:

ITEMS PROVIDED

- (1x) Toolbox
- (2x) Trays
- (2x) J-Hooks
- (2x) Black Flange Screws

1. Toolbox is to be positioned and centralized up front on truck bed.
2. Foam weather strip may be necessary between the toolbox and the front of the bed rail (behind the cab) with the toolbox installation as well. Check the gap to see if the foam weather strip is needed.
3. Take the canister and pull the cover out slightly, letting the lock position/end slat portion hang slightly. Now slide the canister under the toolbox as far as it will go. Then make sure the holes in the canister line up with the hole in the toolbox and secure canister to toolbox on both sides with the black flange screws provided. (Do not fully tighten – just secure).
4. Then take the J Hooks supplied and secure the toolbox to the truck bed rail through pre-drilled holes in toolbox on both sides (Do not fully tighten – just secure).
5. Then install the side rails (see Fitting Side Rails section of Installation Manual). Be sure to lift toolbox slightly and ensure curtain slides into side rail. Once you have installed the side rails and positioned them correctly, go back and tighten the canister screws to the toolbox and J Hooks to truck bed rails.
6. Proceed back to standard Installation Manual instructions for remainder of install.
7. In most cases, one j-hook and one black flange screw per side is all that is necessary.

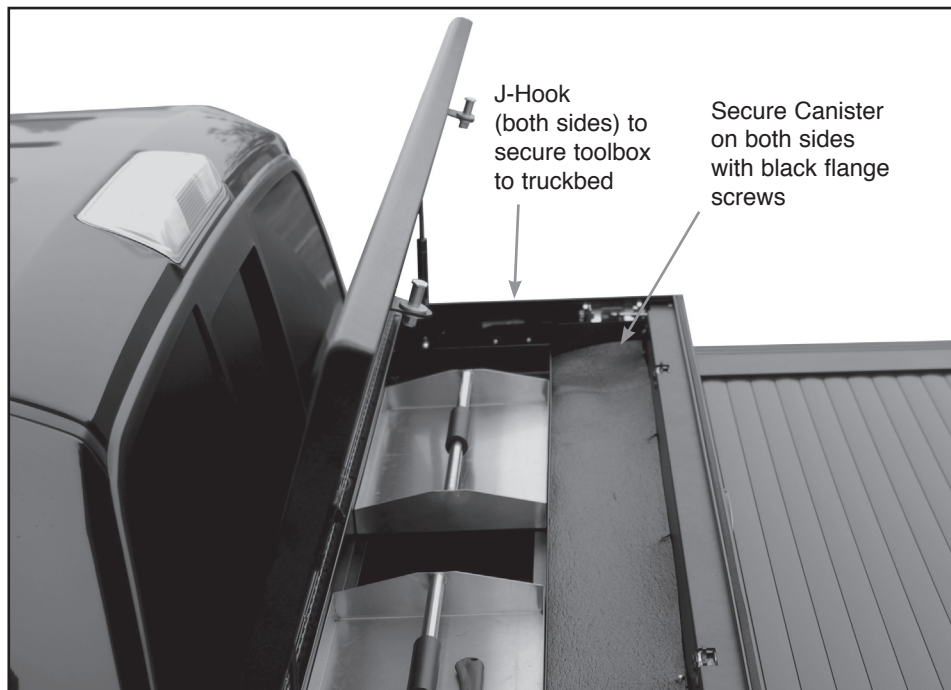

Stainless Steel trays are optional (extra charge), black trays are standard



9. Terms and Conditions

TRUCK COVERS USA, LLC TERMS AND CONDITIONS

Ordering Information:

Hours: Monday through Friday: 7AM – 4PM PST

Fax Orders: (858) 622-0577

Order Line: (858) 622-9135 / (888) 808-2872

Disclaimer: Upon receipt of an order, whether written or verbal, customer acknowledges the following terms and conditions, and agrees to comply. Possession of any of our literature does not constitute an offer to sell. Terms and conditions apply to direct dealers or warehouse distributors only. We sell at wholesale prices to members of the automotive trade and in special circumstances direct to consumers.. Truck Covers USA reserves the right, at our discretion, to discontinue or make any changes deemed necessary to all product or pricing without incurring liability or obligation to our customers. Truck Covers USA is a limited liability company organized under the laws of the State of California.

Prices: Prices are subject to change without notice and will be those in effect at time of shipment.

Terms: The 24 MONTH LIMITED WARRANTY of Truck Covers USA, LLC which applies to all American Roll Covers manufactured and/or sold by Truck Covers USA, LLC are set forth below.

Limited Warranty: All products are guaranteed against defects in material and workmanship for a two (2) year period, from the date of the product being purchased by the original purchaser only. Liability is limited to replacement of parts found to be defective by Truck Covers USA or a designated, qualified representative. Truck Covers USA does not accept any responsibility in connection with the installation of any of its products by its dealers or agents. This limited warranty excludes all labor, paint, and installation charges. This limited warranty also excludes any loss from water damage or theft. This limited warranty further excludes any defect caused by damage in transit, abuse, neglect, accident, parts that have been altered, or parts that have been installed incorrectly. Truck Covers USA, through its authorized dealer, will repair or replace at no expense to the purchaser (excluding labor costs), defects resulting from the manufacturing process. Labor costs to replace defective parts are the responsibility of the purchaser. Not included in this limited warranty are defects resulting from improper installations, abuse, misuse, product modifications, accidents, negligence or deterioration of the finish caused by improper maintenance or exposure to chemicals and/or other unusual environmental conditions. This limited warranty does not extend in any way to accessories or parts not produced by Truck Covers USA. Truck Covers USA does not assume any responsibility for any consequential or incidental damages. This limited warranty is expressly in lieu of all other warranties expressed or implied, including the warranties of merchantability and fitness for a particular purpose and of all other obligations or liabilities to the limited warranty holder on the part of Truck Covers USA. Truck Covers USA neither assumes nor authorizes any other person to assume for Truck Covers USA any other liability in connection with the sale of this product. Without regard to an alleged defect of its products, Truck Covers USA under any circumstances does not assume responsibility for loss of time, inconvenience, revenue, or other consequential damage including, but not limited to, expenses for telephone, food, lodging, travel, loss or damage to the vehicle the products are installed on or loss or damage to personal property of the purchaser or user of the products.

Some states do not permit the exclusion and/or limitation of consequential and/or incidental damages; therefore, this exclusion and/or limitation may not apply to all limited warranty holders.

Limited Warranty Claims: To make a claim under this limited warranty, the claiming party must contact the dealer from whom the product was purchased and inform it of the defect. [Truck Covers USA, LLC may be contacted directly at (888) 808-2872 or direct dial at 858-622-9135]. The dealer will inspect the product and consult with Truck Covers USA, LLC and a determination will be made as to whether the problem falls within the terms of the limited warranty. If Truck Covers USA, LLC determines that there is a defect that falls under the limited warranty, Truck Covers USA, LLC will immediately ship, at no cost to the limited warranty holder, (including freight within continental USA), the part or parts necessary to rectify the defect. In the event that the problem is determined to have been caused by improper installation by the dealer, the dealer will immediately rectify the problem in accordance with Truck Covers USA's authorized dealer limited warranty policy.

If the Truck Covers USA product was purchased through a mail order firm or any other outlet which excluded the service of installation and the installation was performed by anyone other than an authorized dealer of Truck Covers USA, LLC, the limited warranty coverage is limited to replacement of parts only. To make a claim, you must first contact Truck Covers USA, LLC at (888) 808-2872 and a determination will be made as to whether it will be necessary to return the product to Truck Covers USA. The part must be properly packaged and returned at the expense of claimant to Truck Covers USA/ Limited Warranty Department at the address below. A brief description of the problem must be enclosed inside the packaging. If the part(s) are found to be defective, a new part(s) will be shipped to you at the expense of Truck Covers USA, LLC, (within continental USA only).

Limited Warranty Returns: All Returns must be prior approved by Truck Covers USA. Upon Request, to Truck Covers USA, and after approving the return, Truck Covers USA will issue an RGA number. No returns will be accepted without an RGA number (Return Goods Authorization) obtained from Truck Covers USA. The RGA number must appear on the outside of the package and on all shipping documents.

RETURNS WILL BE ACCEPTED IN ORIGINAL PACKAGING ONLY

Shipment: All prices are FOB San Diego, California. Orders will be shipped by truck. Truck Covers USA is not able to ship its covers via UPS (United Parcel Service). Merchandise received damaged via shipping and/or any shortages must be reported within 48 hours of receipt if damage is concealed. All original packaging must be held for inspection. If, however, shipment is delivered/shipped by truck and arrives with visible damage (not concealed damage) you are required to refuse the delivery and notify Truck Covers USA immediately otherwise, once you accept your order you take full responsibility for damage.

Stock Adjustments/New Returns: Returned merchandise must be accompanied by a return goods authorization ("RGA") number, a return invoice listing quantities and part numbers, and be in new condition with all accompanying installation hardware included. All returns are subject to a minimum of a 20% restock fee. Upon inspection and approval of stock adjustments/new RGA number returns, any credit(s) due will be issued to your account. Obsolete stock as defined by Truck Covers USA will not be accepted for return. ONLY new product(s) in original packaging will be accepted for return.

Refusals: Truck Covers USA will permanently drop any dealer who returns a shipment marked "REFUSED", or refuses to accept any shipment for any reason. Any refused shipments sent back to Truck Covers USA does not constitute the right to a refund or a credit. It is the customer's responsibility to make the necessary arrangements with Truck Covers USA for the refused shipment. It is company policy to charge the customer freight charges associated with the shipment and a 20% restocking fee.

Truck Covers USA, LLC
8970 Crestmar Point
San Diego, CA 92121-3216



Built to Last!

**THE FINEST
ROLL COVERS &
ACCESSORIES
ON EARTH**



The Finest Roll Covers, Toolboxes & Accessories on Earth!

Truck Covers USA, LLC
8970 Crestmar Point
San Diego, CA 92121-3216

www.truckcoversusa.com